

29520 FETAL MONITOR GIMA FC700B3

# OPERATION MANUAL

## Fetal Monitor Operation Manual

Rev 2.51

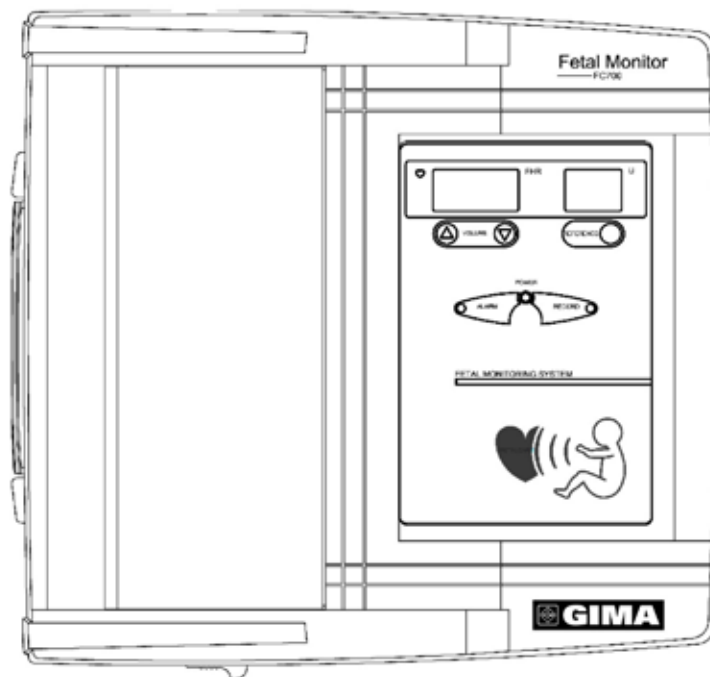

# Terms of Warranty

This product is manufactured and passed through strict quality control and inspection.

Compensation standard concerning repair, replacement, refund of the product complies with "Consumer's protection law" noticed by Economic Planning Dept.

We provide a 1-year warranty period for main body, but Accessory provides a 6 months warranty period. (Two years in Europe)

We will repair or replace any part of the FC-700 found to be defective in usual operating circumstance for free to you.

This warranty does not apply to any defect caused by improper abuse, misuse or exposure to poor management.

## WARNING



Federal law restricts this device to sale by or on the order of a physician.

## How to reach us

The following are telephone numbers and addresses for contacting various service, product supplies and sales personnel

**Purchase  
Inquiry**

**GIMA SPA**

Via Marconi, 1 – 20060 GESSATE (MI) ITALY  
Tel : ++39 02 953854209 Fax : ++39 02 95380056  
E-mail : [export@gimaitaly.com](mailto:export@gimaitaly.com)

**Manufacturer**

**Bionet Co., Ltd.**

#1101 11F E&C Venture Dream Tower3 38-21, Digital-Ro 31-Gil,  
GURO-GU, SEOUL, SOUTH KOREA (ZIP 08376)  
Overseas sales dept. Tel : +82-70-7585-6418  
E-mail : [sales@ebionet.com](mailto:sales@ebionet.com)

**Service call**

VIA Marconi, 1 – 20060 GESSATE (MI) ITALY  
Tel : ++39 02 953854209 Fax : ++39 02 95380056  
E-mail : [export@gimaitaly.com](mailto:export@gimaitaly.com)

**Technical  
support**

Per questioni tecniche o problemi con il dispositivo, contattare:  
Via Marconi, 1 – 20060 GESSATE (MI) ITALY  
Tel : ++39 02 953854209 Fax : ++39 02 95380056  
E-mail : [export@gimaitaly.com](mailto:export@gimaitaly.com)

**Web site**

URL : <http://www.gimaitaly.com>  
URL : <http://www.bio2net.com>

In the event of malfunction or failure, contact us along with the model name, serial number, and product name of the equipment.

# Definition of Warning, Prohibition, Mandatory Action and Note

- For a special emphasis on agreement, terms are defined as listed below in operation manual. Users should operate the equipment according to all the Warning and Caution instructions.
- Manufacturer or Sales agency takes no responsibility for any kind of damage or breakdown that is caused by misuse and failure to maintain the equipment.

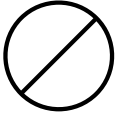
PROHIBITION	
	To inform that it may cause serious injury or death to the patient, property damage, material losses against the “warning” sign.







WARNING	
	To inform that it may cause no harm in life but lead to injury against the “Caution” sign.

MANDATORY ACTION	
	Per informare che si deve procedere per il funzionamento e manutenzione sicuri dell' apparecchiatura.

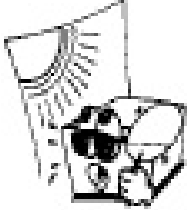
NOTE	
To inform that it is not dangerous but important “note” sign for proper installation, operation, and maintenance of the equipment.	

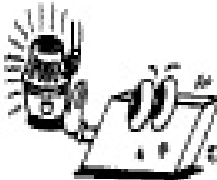
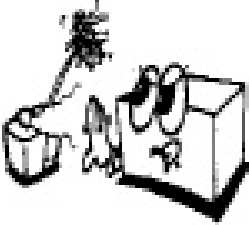
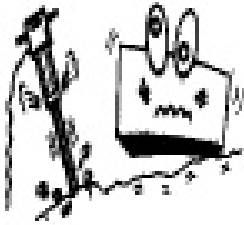
# General Precaution on Environment

Do not keep or operate the equipment in the environment listed below.

	<p>Avoid placing in an area exposed to moist. Do not touch the equipment with wet hand.</p>		<p>Avoid exposure to direct sunlight.</p>
	<p>Avoid placing in an area where there is a high variation of temperature. Operating temperature ranges from 10°C to 40°C. Operating humidity ranges from 30% to 85%.</p>		<p>Avoid in the vicinity of Electric heater.</p>
	<p>Avoid placing in an area where there is an excessive humidity rise or ventilation problem.</p>		<p>Avoid placing in an area where there is an excessive shock or vibration.</p>
	<p>Avoid placing in an area where chemicals are stored or where there is in danger of gas leakage.</p>		<p>Avoid dust and especially metal material into the equipment.</p>
	<p>Do not disjoint or disassemble the equipment. GIMA SPA takes no responsibility of it.</p>		<p>Power off when the equipment is not fully installed. Otherwise, equipment could be damaged.</p>

# General Precaution on Electric Safety

Check the items listed below before operating the equipment:

- Be sure that power supply line is appropriate to use. (Power Adaptor Input: 100 - 240V AC, 50-60Hz, 1.5A, Output: 18V, 2.8A).
- Be sure that the entire connection cable of the system is properly and firmly fixed.

## NOTE

The equipment should not be placed in the vicinity of electric generator, X-ray, broadcasting apparatus to eliminate the electric noise during operation. Otherwise, it may cause incorrect result. Self-power line is important for FC-700. To use same power source with other electric instruments may cause incorrect result. Warning statement for class I me equipment indicating: "warning: To avoid risk of electric shock, this equipment must only be connected. Warnings regarding significant risks of reciprocal interference posed by me equipment during specific investigations or treatments.

## NOTE

FC-700 is classified as listed below:

- This equipment conforms to Class I, Type-BF.
  - Do not use the equipment in the vicinity of flammable anesthetics and solvents.
  - The equipment conforms to Class I according to IEC/EN 60601-1 (Safety of Electric Medical Equipment).
- This equipment conforms to Level B according to IEC/EN 60601-1-2 (Electromagnetic Compatibility Requirements).

## NOTE

Accessory equipment connected to the analog and digital interfaces must be certified according to the respective IEC standards ( e.g. IEC 950 for data processing equipment and IEC 601-1 for medical equipment ). Furthermore all configuration shall comply with the system standard EN 60601-1-1:1993.  
If in doubt, consult the technical service department or your local representative.

## NOTE









Please check the below.

- The protective earth connection points connect separated adapter.
- FC-700 obtain certification adapter to use, so don't have to test this equipment.
- This equipment doesn't have protective earth connection point.
- Authenticated adapter is the equipment that has passed through the protective earth connection test.
- Protective earth connection test is the equipment itself is replaced by a test of the certified adapter.
- Therefore, there is no need to test the protective earth connection point with this equipment.

## Safety Symbols

The International Electrotechnical Commission (IEC) has established a set of symbols for medical electronic equipment which classify a connection or warn of any potential hazards. The classifications and symbols are shown below.

### Save these instructions

SYMBOLS	CONTENTS
	Isolated patient connection. (IEC 601-1-Type BF).
	Device part switched off.
	Device part switched on.
	Equipotential Stud: A ground wire from another device can be tied here to ensure the devices share a common reference.
	External Signal IN/OUT Port.
<b>IPX1</b>	Protection against vertically falling water drops(IEC 60529) Water Protection Specification Level 1.
	Follow operating instructions (IEC 60878 Safety).
	Consult accompanying documents.
	This symbol indicates that waste electrical and electronic equipment must not be disposed of as unsorted municipal waste and must be collected separately.

## Table of Contents

Table of Contents	8
<b>Chapter 1. General Information</b>	<b>10</b>
1) Product Overview	10
2) Product Features	10
3) Product Configuration	10
4) Explanation of Sections of Output Sheets	16
5) CardioTocoGraph(CTG) Analysis output paper area	17
6) Installazione del prodotto	19
<b>Chapter 2. How to Use FC-700</b>	<b>21</b>
1) Basic operation	21
2) Function of Keys	21
3) FHR Measurement	22
4) UC Measurement	24
5) Measurement of Fetal Movements	25
6) Recording	26
7) FHR Alarm	27
8) Volume Control	27
9) Equipment State Alarm	28
<b>Chapter 3. Setup Modes</b>	<b>29</b>
1) Alarm/Time Setup	29
2) Recording Setup	32
3) Factory Setup	35



<b>Chapter 4. CTG Terminology</b>	36
1) Baseline FHR	36
2) Acceleration	36
3) Late Deceleration	36
<b>Chapter 5. Trouble shooting</b>	39
1) Maintenance and Cleaning	39
2) Regular Inspection	40
3) Error Message	40
<b>Chapter 6. Specifications</b>	41
Appendix A Maintenance, Care, and Service	43
Appendix B Ultrasound Power	45
Appendix C Abbreviation and Symbol	48
Appendix D Electromagnetic Emissions and Immunity - Manufacturer's declaration	49

# Chapter 1. General Information

## 1) Product Overview

FC-700 is the fetal monitor that measures the fetal heart rate and uterine contraction. FC-700 irradiates ultrasound wave to the abdomen of a pregnant woman, and detects the Doppler frequency signal reflected from the heart of the fetus. FC-700 analyzes this signal and displays the heart rate by LED. Also, FC-700 provides the sound from the heart of fetus. FC-700 measures the uterine contraction of a pregnant woman by pressure sensors and displays the numerical values. And FC-700 records the heart rate of the fetus, fetal movement and the values of uterine contraction.

### Intended use

FC-700 is the fetal monitor that measures, displays numerical value of measured results by LED, prints graphically the fetal heart rate and uterine contraction of a pregnant woman, and also provides the sound from the heart of fetus. It is intended to aid comprehensive assessment for the well being of single fetus.

It intended to be used by trained healthcare personnel. It is not intended for home use.

## 2) Product Features

- FC-700 records the heart rate of the fetus, fetal movement and the uterine contraction of a pregnant woman, and basic information of the equipment with wide A4 Size paper.
- FC-700 can use general fax paper as well as thermal paper for fetal monitor.
- FC-700 has automatic NST function which records FHR, UC and fetal movement only for the established time.

## 3) Product Configuration

FC-700 system consists of the following. Unpack the package and check the followings are included. Also, be sure to check any damage to the main body and accessories.

1. FC-700 main body
2. Ultrasound Doppler Probe (1 EA)
3. UC Probe (1EA)
4. Event Mark Jack (1EA)
5. Print Paper (1EA)
6. Power Adaptor (1EA)
7. Power Cord (1EA)
8. Ultrasound Gel (1EA)
9. Probe Belt (2EA)
10. Operation Manual (1EA)

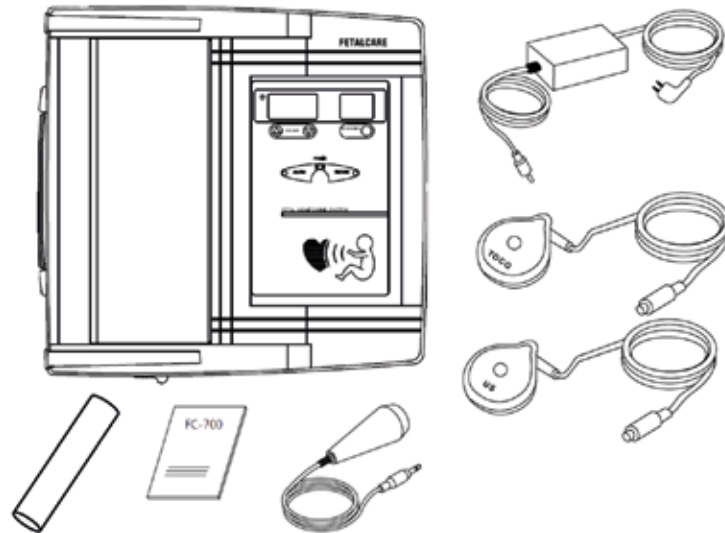





**WARNING**



- Do not reuse the ultrasonic gel.
- Warnings regarding significant risks of reciprocal interference posed by me equipment during specific investigations or treatments.
- Information on potential electromagnetic or other interference and advice on how to avoid or minimize such interference.
- A warning statement addressing hazards that can result from unauthorized modification of me equipment according to following examples: only can fix the Service person of GIMA SPA.
- Power supply is specified as a part of ME Equipment.

**Safety Symbols Marked on the Package**

SYMBOLS	CONTENTS
	Show a direction of top.
	Keep dry.
	Fragile.
	Not to use hook.

## Main Body configuration

### Top view

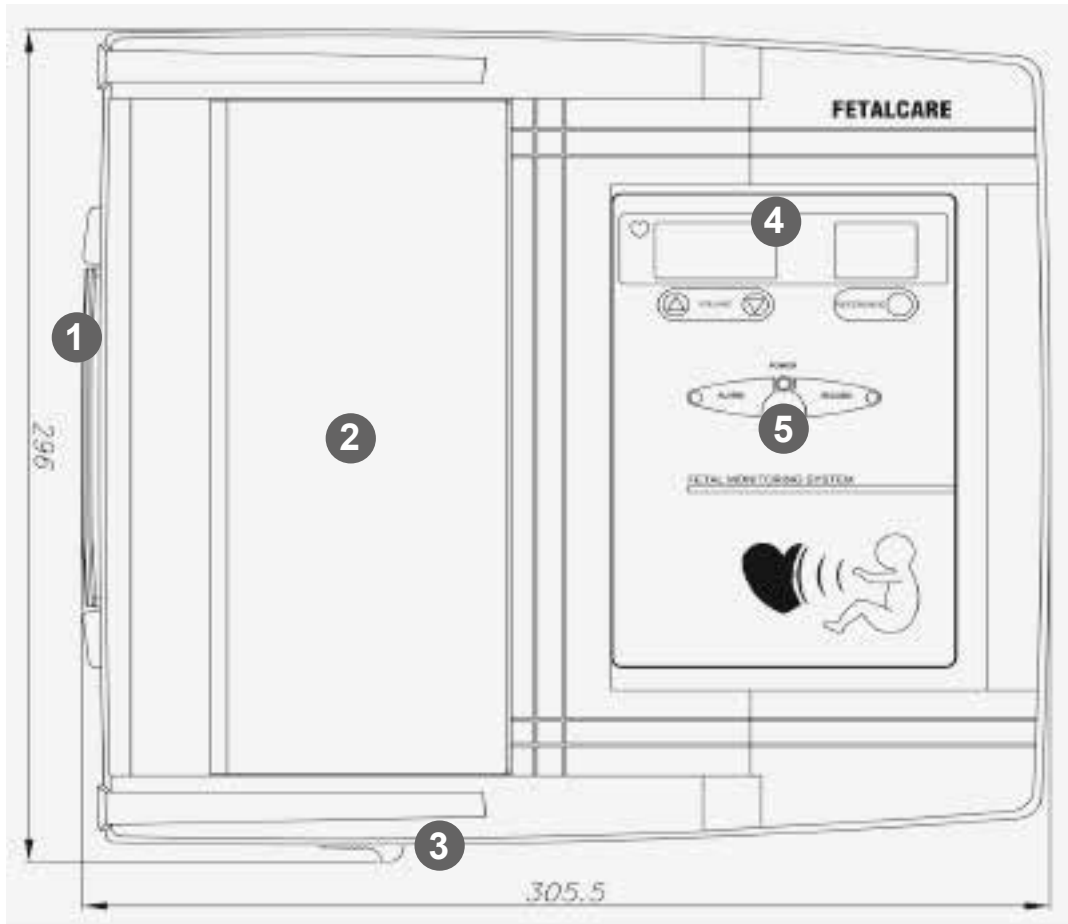

1. Hand Grip.
2. Printer door.
3. Printer door release button.
4. Display LED.
5. Control panel.

## Front view

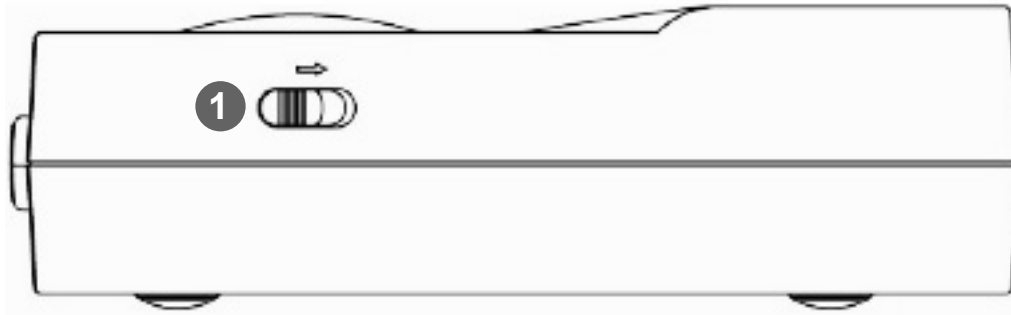

1. Printer door release button.

## Rear view

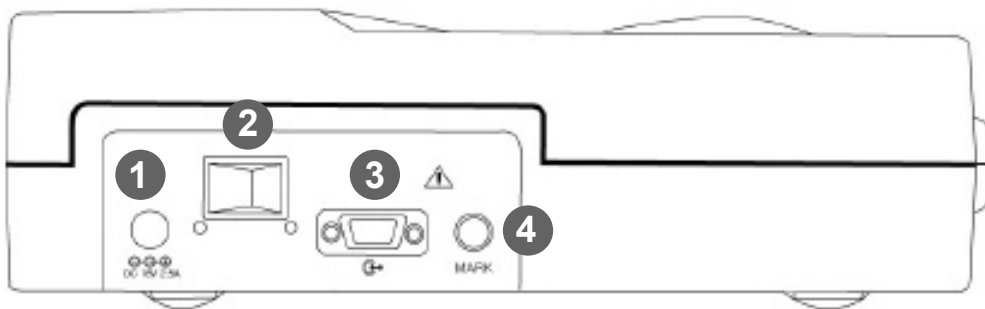

1. Power adaptor connection port .
2. Power on/off switch.
3. RS-232C serial port.
4. Mark Jack connection port.

### PROHIBITION

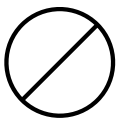

Please instruct the operators to avoid contact with both the RS-232C Serial port area and the patient simultaneously. To avoid an expected electric shock, do not open the equipment cover or disassemble the equipment. Refer servicing to qualified personnel of GIMA SPA.

### Left side view

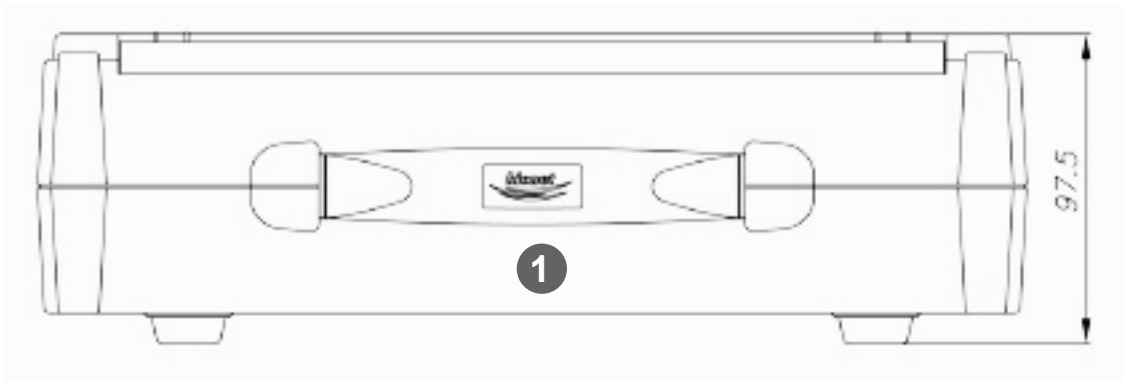

1. Hand Grip.

### Right side view

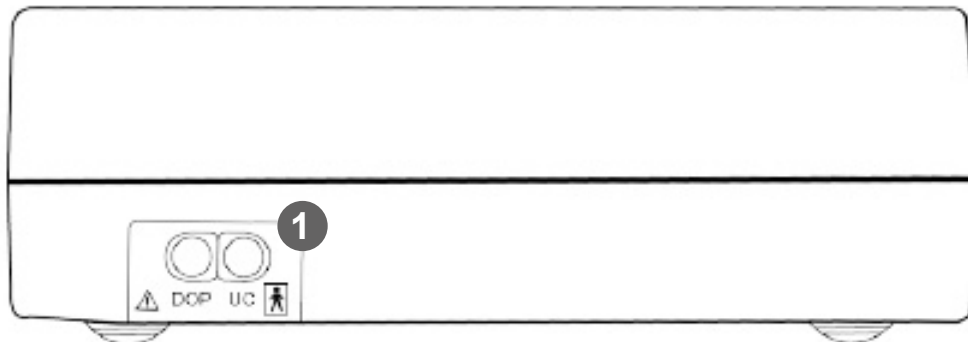

1. Doppler UC Probe connection port.

### NOTE

To avoid an expected electric shock, do not open the equipment cover or disassemble the equipment. Refer servicing to qualified personnel of GIMA SPA.

## Control Panel

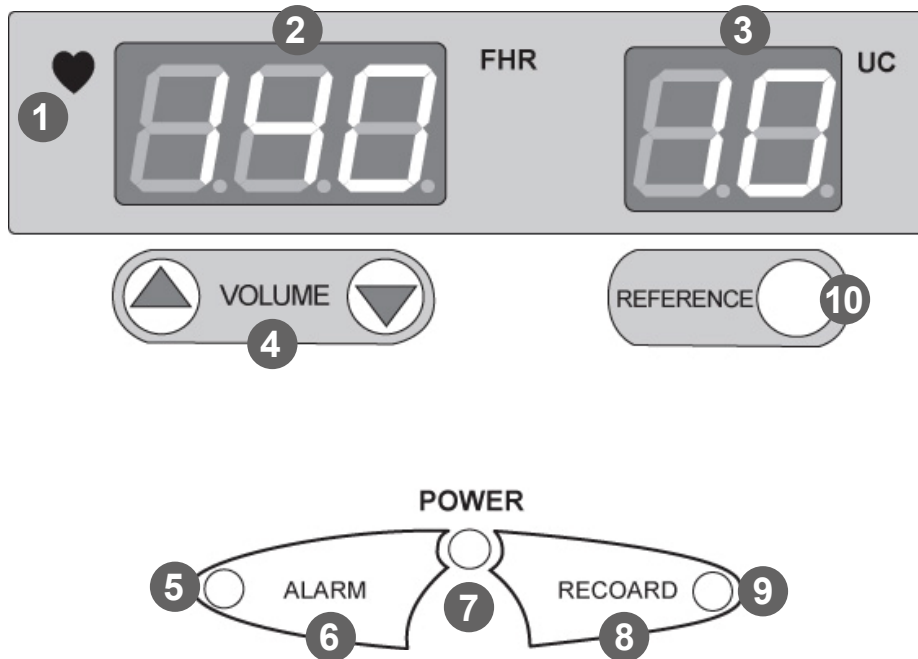

1. Heart rhythm symbol (Green: stable, Red: unstable).
2. Heart rate of the fetus (bpm).
3. UC measurement value.
4. Volume up/down key. During the use of the Menu for setup, this key is used to change the setting value.
5. LED of the alarm on/off .
6. Alarm on/off key. During the use of the Menu for setup, this key is used to set the function of the time and date.
7. LED of the power on/off .
8. Print on/off Key. When setup mode, store the setting value. When out of print, paper feeding function.
9. LED of the print on/off .
10. Key setting UC value as reference value(10). When setup mode, printing related functions setup.

## 4) Explanation of Sections of Output Sheets

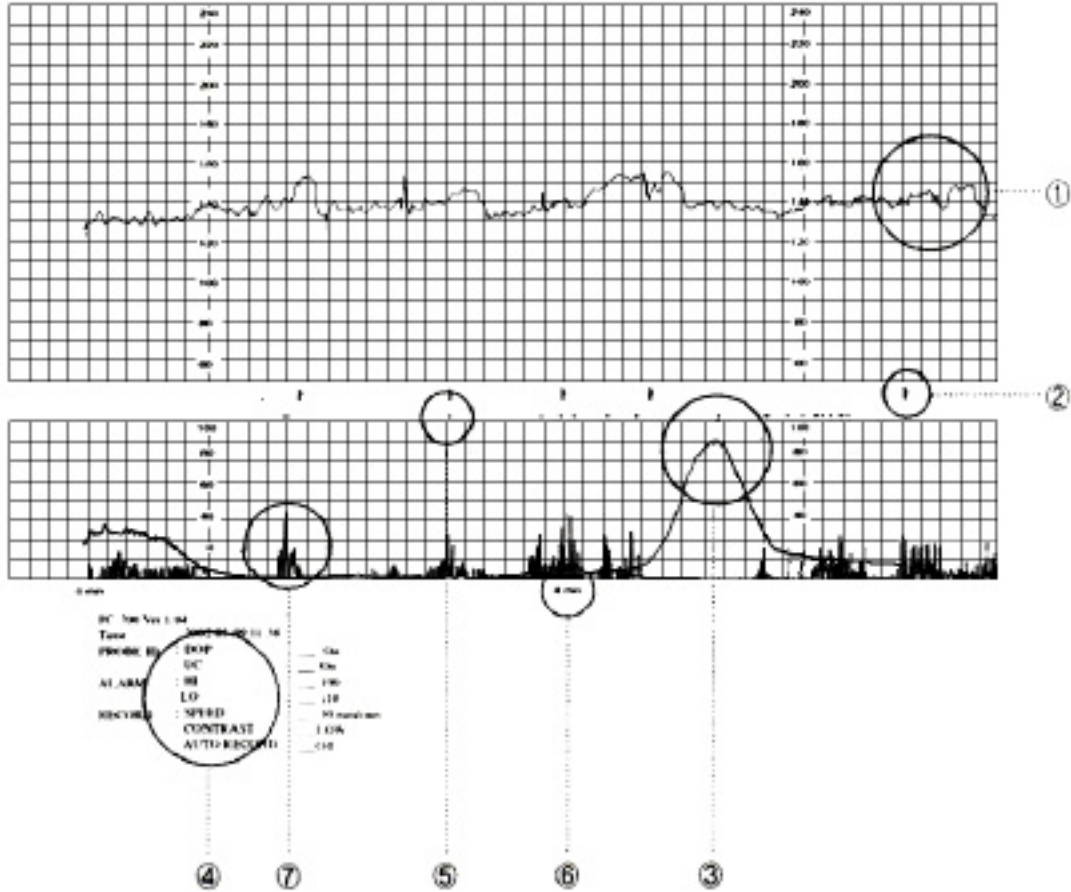

1. Fetal heart rate per minute.
2. Fetal movement point that is indicated when Event Marker is pressed.
3. Uterine contraction.
4. Information on the recording condition.
5. Fetal movement point when an automatic fetal movement is detected.
6. Recording time.
7. Strength and intervals of automatic fetal movements when they are detected.



## 5) CardioTocoGraph(CTG) Analysis output paper area (Option)

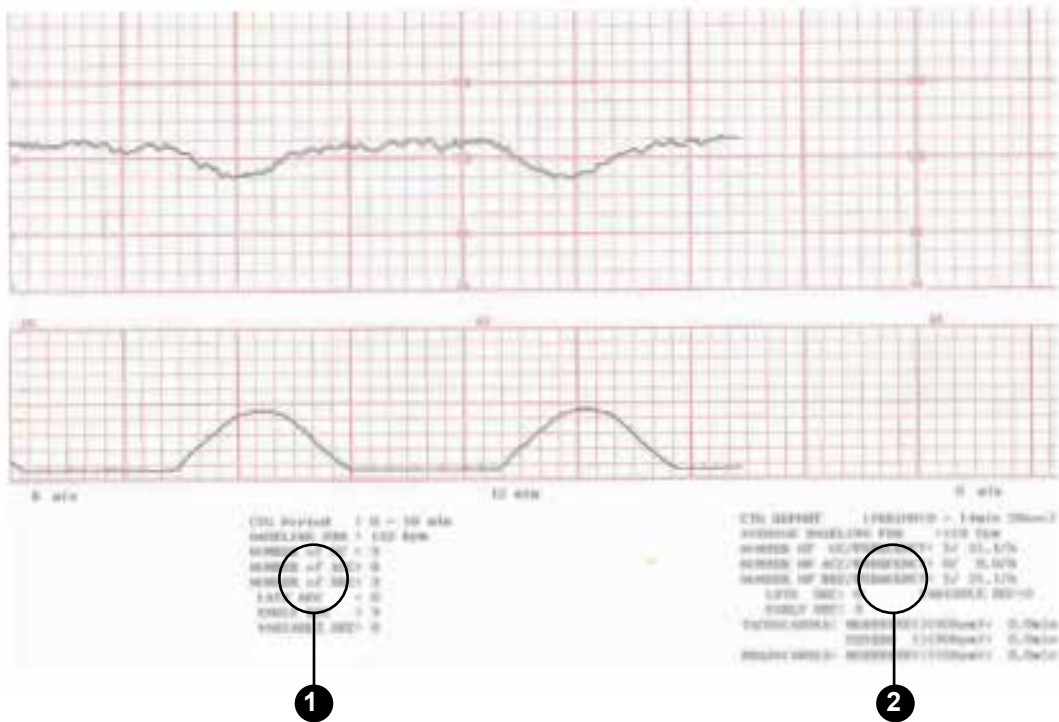

CTG Analysis results is printed out every 10 minute. (Intermediate Report)

Start printing by pressing print button in order to analyze CTG and repress print button to stop printing process. CTG analysis results will be printed. (Final Report)

You have to obtain data at least for 10 minutes.

< Intermediate Report >

CTG Period	: 0-10 min	Time during which CTG is analyzed
BASELINE FHR	: 123 bpm	Mean of Baseline FHR during the period
NUMBER of UC	: 3	Number of UC during analysis period
NUMBER of ACC	: 0	Number of Acceleration during the period
NUMBER of DEC	: 3	Number of Deceleration during the period
LATE DEC	: 0	Number of Late DEC during DEC
EARLY DEC	: 3	Number of Early DEC during DEC
VARIABLE DEC	: 0	Number of Variable DEC during DEC

< Final Report >

CTG REPORT (PERIOD : 0 - 15 MIN 0 SEC)	
AVERAGE BASELINE FHR(BPM)	: 123 bpm
NUMBER OF UC(FREQUENCY)	: 5/ 20.0/h
NUMBER OF ACC(FREQUENCY)	: 0/ 0.0/h
NUMBER OF DEC(FREQUENCY)	: 5/ 20.0/h
LATE DEC	: 0
EARLY DEC	: 5
VARIABLE DEC	: 0
TACHYCARDIA : MODERATE(>160BPM)	: 0.0 min
SEVERE(>190BPM)	: 0.0 min
BRADYCARDIA : MODERATE(<110BPM)	: 0.0 min
SEVERE(<90BPM)	: 0.0 min

- Period : Time during which CTG is analyzed
- Average Baseline FHR(bpm) : Mean number of Baseline FHR during above period
- Number of UC(Frequency / h) : Number of UC and frequency of UC per hour during the period
- Number of ACC(Frequency/h) : Number of Acceleration and frequency of Acceleration per hour during the period
- Number of DEC(Frequency /h) : Number of Deceleration and frequency of Deceleration per hour during the period
- Late DEC : Number of Late Deceleration during Deceleration
- Early DEC : Number of Early Deceleration during Deceleration
- Variable DEC : Number of Variable DEC during Deceleration
- TACHY : MODERATE(>160bpm) : Time in minute during which FHR is 160~190 bpm
- TACHY : SEVERE(>190bpm) : Time in minute during which FHR is greater than 190 bpm
- BRADY : MODERATE(<110bpm) : Time in minute during which FHR is 110~90 bpm
- BRADY: SEVERE (<90bpm) : Time in minute during which FHR is smaller than 90bpm

## 6) Product Installation

### Basic Operation

Pay attention to the following in installing FC-700:

- Use it at the temperature between 10 and 40 degrees centigrade and at the humidity between 30 and 85 percent.
- Check plug-in and treat the Probe Cable carefully.
- Don't put several plugs in an outlet.
- Install the main body at the flat place.
- Avoid using a plug making a noise in plug-in.
- All the setup will be recorded at the interior memory even when it is switched off and then on.
- Be careful, as it is easy to break by the shock.
- Install it away from dust or inflammable things in consideration of the temperature and humidity..

### Power Supply

Use free voltage of AC between 100 and 250V(50-60Hz, 1.2A). If a plug is put in an outlet, the "POWER" LED at operation panel will be turned on green. Within the equipment is a battery to change the date and time even when it is switched off. Use a Type CR2032 3V Lithium Battery.

### MANDATORY ACTION



Don't throw away batteries carelessly to protect environment, but ask the hospital for the designated places to dump batteries according to proper procedure.  
Only, use the FC-700 Adapter please.

### Plug-in

Put the plug in an outlet of 110V or 220V and connect one side of power cable to the power adaptor. If you put the plug of power adaptor in the terminal of power adaptor of the main body of FC-700 and then switch it on, the equipment will work. If the power supply is normal, LED at the operation panel indicating Power On/Off will be turned on green.

## Connection of the Probe Cable

Connect the Probe Cable to the Probe Cable terminal at the right side of the main body.  
Connect the Doppler Probe to the "DOP" terminal and the UC Probe to the "UC" terminal.  
Connect Mark Jack to the "MARK" terminal at the backside of the main body.

### NOTE

Probe cable must be connected with device power is on.

## Setting of Recording Paper

If you release the button to open the printer cover at the front of FC-700 to the right, it will open. Put recording paper with the recording part on the upper side adjusting the paper roll parallel to the print direction and then close the cover.

### MANDATORY ACTION



Only use the FC-700 paper please.

## Software Version

The information in this manual only applies to FC700 patient monitor software version 3.06 Due to continuing product innovation, specifications in this manual are subject to change without notice. You can see from the paper below.

# Chapter 2. How to Use FC-700

## 1) Basic operation

1. Put the plug of FC-700 in an outlet and switch it on.
2. Check setup values if they are set as wished.
3. Change the setup values, as you want.
4. Put the Doppler Probe and the UC Probe on a pregnant woman using a belt.
5. Give her Mark Jack to press when she feels fetal movements.
6. Press "REFERENCE" Key to set the UC value at a zero.
7. Control the volume to hear fetal heart beat well.
8. If the accurate heart rate is indicated, press the Record Key to start printing it.

## 2) Function of Keys

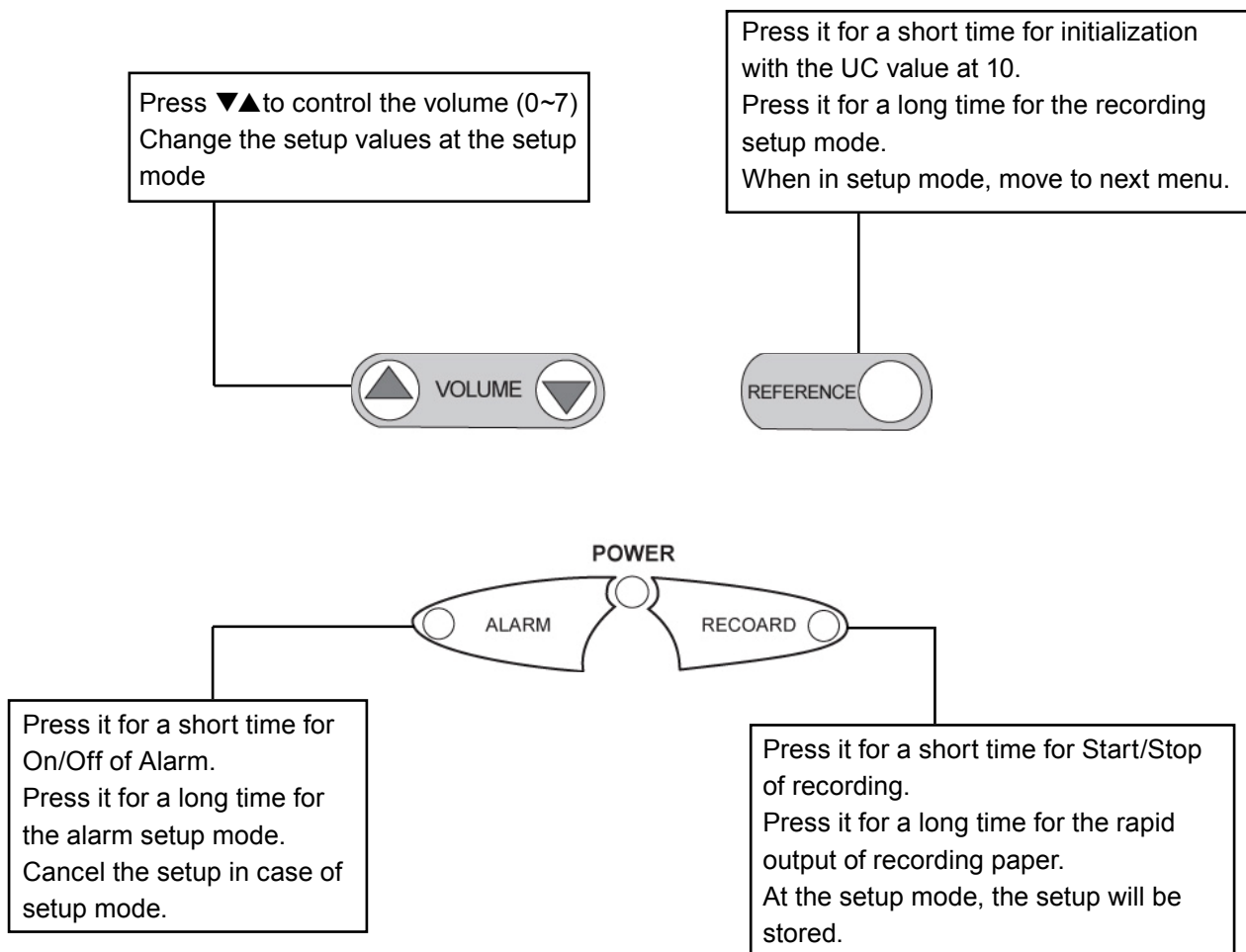

**LAMP**

POWER: If it is switched on, the lamp will be turned on green.

ALARM: If the alarm is on, the lamp will be turned on red.

RECORD: During printing, the lamp will be turned on green.

♥ (Heart Rhythm): The lamp will be turned on and off green when the signal is stable according to heart beat and red when it is unstable

**3) FHR Measurement**

To measure FHR (Fetal Heart Rate), use an ultrasonic Doppler effect to catch the fetal heart beat, and then compute the real-time heart rate per minute to record. To minimize the reduction of ultrasonic waves in the air, apply a sufficient amount of ultrasonic gel on the surface of Doppler Probe to eliminate its air layer.

**Connection of the Probe**

Connect the Doppler Probe to the "DOP" terminal at its right side.

**Basic Action According to the Connection of the Doppler Probe**

If the Doppler Probe is not connected to the main body, there is no indication at the FHR indication section. If the Doppler Probe is connected to the main body, on the FHR indication section appears "---" which indicates that the preparation for measurement has been finished. If probe is disconnected from the main body, a warning signal of "Ding-dong" is made. This signal disappears when the Probe is connected again or any of keys on the operation panel is pressed

**FHR Measurement**

1. Put the belt to fix the Doppler Probe beneath the waist of a pregnant woman.
2. Apply a sufficient amount of ultrasonic gel on the Doppler Probe to remove bubbles between her abdomen and the surface of Doppler Probe.
3. Feel her abdomen and find the back part of a fetus to put the Doppler Probe on. When the fetus is in a lateral position, put the Probe on the part as follows:

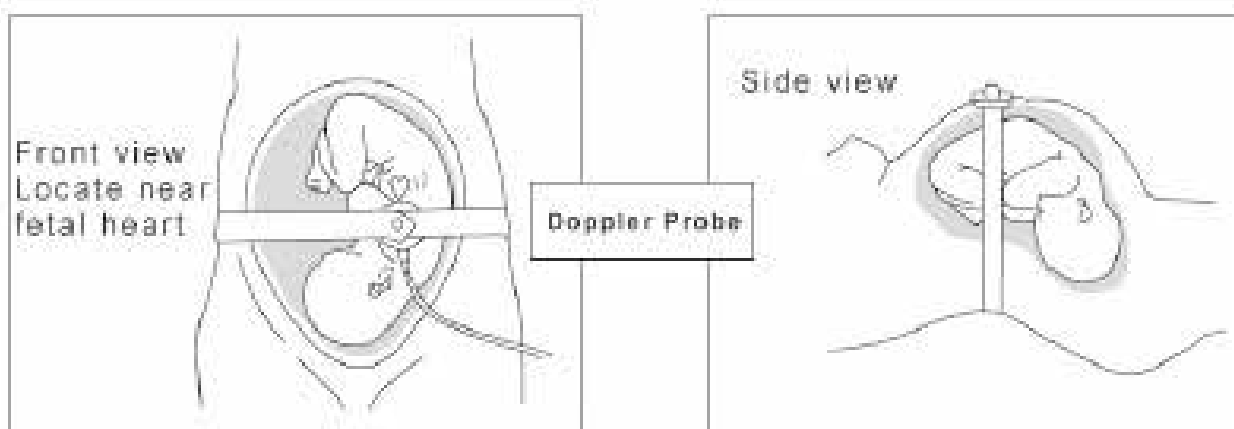

### NOTE

When the Doppler Probe is put not on the back but on the breast part of a fetus, accurate ultrasonic waves can't be caught from the fetal heart and the fetal heart beat can be frequently missed.

4. After moving the Doppler Probe little by little to find the section where the fetal heart beat sounds relatively loud and clear and the heart rhythm lamp flickers according to the fetal heart beat, control the volume so that the heart beat can have a proper (sound) loudness.

5. Put the button at the upper part of the Doppler Probe into a hole of the belt to fix the Probe.

### NOTE

Fix the Probe Cable toward the head part of a pregnant woman in order to prevent it from being damaged, and for moving to some degree comparatively.

6. It takes 2~4 seconds calculating and indicating FHR. When the stable FHR is indicated, start to record it.

## 4) UC Measurement

UC (Uterine Contraction) can be measured with an externally attached pressure sensor. If the UC Probe is put on the abdomen of a pregnant woman, it measures a relative pressure changing according to the uterine contraction and records uterine contraction.

### Probe Connection

Connect the UC Probe to the "UC" terminal at its right side.

### Basic Actions According to the Connection of the UC Probe

If the UC Probe is not connected to the equipment, there is no indication at the UC indication section. If the UC Probe is connected to the equipment, there appears a value of "10" which indicates that the preparation for measurement has been finished. If a line of the UC Probe is down or the Probe is disconnected from the main body, a warning signal of "Ding-dong" is made. This signal stops when the Probe is connected again or any of keys on the operation panel is pressed.

### UC Measurement

1. Put the belt beneath the back part of a pregnant woman to fix the Probe.
2. Put the UC Probe on the Fundus (approximately 10 centimeters away from the navel upward) or on the part that a lump is firstly made at her abdomen.
3. Put the button projected from the upper part of the UC Probe into a hole of the belt to fix the Probe. Control the belt to set the UC value between 20 and 90.
4. Press the REFERENCE Key on the operation panel to set the standard value at 10.
5. If the stable UC value is indicated on the UC indication section, start to record it.

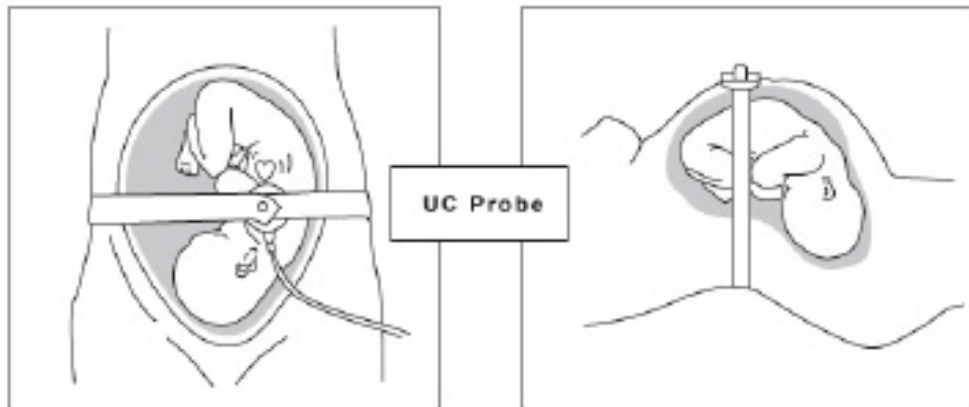

### NOTA

If the UC Probe is connected to the equipment but not used, unreliable value may be indicated on the UC indication section.



## 5) Measurement of Fetal Movements

### How to Use Event Marker

Event Marker relies on the recognition of a pregnant woman to record a fetal movement point: when she feels a fetal movement, press a button on Event Marker. When Event Marker is pressed during recording, the fetal movement point is indicated with an arrow mark on recording paper with a signal of "Beep~"

### How to Use the Automatic Fetal Movement Measurement

The automatic fetal movement measurement extracts information proportional to strength and intervals of fetal movements from the received ultrasonic Doppler signal and records it with a uterine contraction graph at recording paper. If it exceeds the established critical loudness value of fetal movements, record the fetal movement point with a dot between the FHR graph and the UC graph. It can be used as follows:

1. Set the "FM+FMD" menu at '1' at the recording setup mode to enable the automatic fetal movement measurement function to work. (See Paragraph 2 of Chapter 3 "Recording Setup"). Value '1' is [FM+FMD], '2' is [FMD Only], and '0' is [Off].
2. Set the "thr" menu at the value between 5 and 95 for the critical strength value of fetal movements at the factory setup mode. If the maximum strength of fetal movement is regarded as 100, record the fetal movement point with a dot between FHR and UC when it exceeds the setup. (See Paragraph 3 of Chapter 3 "Factory Setup")
3. When "thr" menu is at '0', doesn't mark with a dot.
4. Set the "FM" item at '0' at the recording setup mode in order not to use the automatic fetal measurement function.

< "1" FM + FMD >

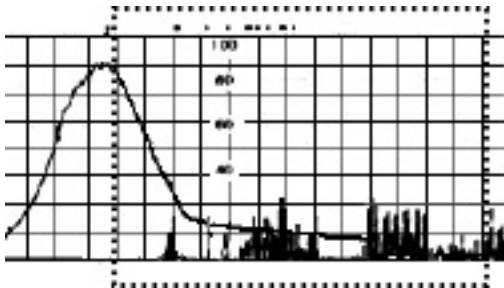

< "2" FMD only >

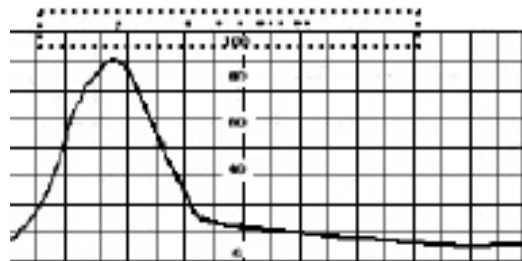

< "0" FM off >

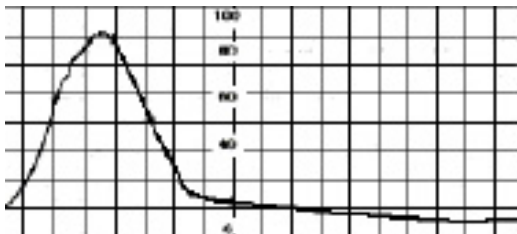

## 6) Recording

The recording functions include AUTO NST (Non-Stress Test) and monitoring. The AUTO NST function that records FHR, UC, and fetal movements for the period of established time and stops automatically is effective in the non-contraction test. The monitoring function enables a user to operate Start/Stop of recording.

### Order to Use the AUTO NST Function

- Set the "Prd" menu at one value of '10, 20, 30, 40, 50, and 60' at the recording setup mode to set automatic recording time. The unit is a minute. (See Paragraph 2 of Section 3 "Recording Setup")
- Put the Doppler and UC Probe on a pregnant woman in the way of 3) and 4), and press the Record Key when the fetal heart beat is identical to the FHR value.
- Implement recording for the period of time established at the "Prd" menu. During recording, left time is indicated as "t20" at the FHR indication section at 5-minute intervals for a second.
- After the period of established time, recording stops automatically, "End" is indicated, and an alarm of "Ding-dong~" is made. Press any of keys on the operation panel to make "End" disappear and to stop an alarm.
- Press the Recording Key during recording to stop recording.
- Press the Record Key for a long time to output a recording paper rapidly.

### Order to Use the Monitoring Function

- Set the "Prd" item at '0' at the recording setup mode.
- Put the Doppler and UC Probe on a pregnant woman in the way of 3) and 4), and press the Record key when the fetal heart beat is identical to the FHR value.
- Press the Record key again to stop recording.
- Press the Record Key for a long time to output a recording paper rapidly.

## 7) FHR Alarm

If FHR beyond the established upper or lowest limit of normal FHR exceeds the established delay time, an alarm is made.

### Order to Use the FHR Alarm Function

- Use the Volume Up/Down Key to set the value of “H” menu which means the upper limit of FHR and that of “L” menu which means the lowest limit of FHR as you wish at the alarm setup mode. Be careful to set the value of “H” higher than that of “L”. (See Paragraph 1 of Chapter 3 “Alarm/Time Setup”)
- If abnormal FHR is maintained for some time at the factory setup mode, set the delay time “t” menu at one value of “10, 20, 30, 40, 50, and 60” to determine whether or not to raise an alarm. The unit is a second. (See Paragraph 3 of Chapter 3 “Factory Setup”)
- Check if the ALARM lamp is on. If it is off, it means that the FHR alarm function is off; so press the Alarm key to turn on the ALARM lamp.
- FHR beyond the upper or lowest limit of FHR alarm exceeds the established duration, a signal of “Beep, beep, beep” is made.
- To stop the signal, press the Alarm key and let the FHR alarm function off. Then, the ALARM lamp will be off, indicating that the FHR alarm function is off.

## 8) Volume Control

The fetal heart beat sound measured with the Doppler Probe is outputted through the built-in speaker, (within the equipment) and its loudness is controlled with the Volume Up/Down Key. The volume is at eight levels from 0 to 7.

- Press the Volume Up/Down Key once to indicate the currently established value of volume at the FHR indication section for two seconds.
- Press the Volume Up/Down Key within two seconds to change the value of volume which will then apply to the volume of speaker.
- Don't press any key for two second to store the value of volume indicated at the FHR indication window and then return it to the basic state.
- The stored value of volume can be applied even when the equipment is switched off and then on.

## 9) Equipment State Alarm

The following circumstances raise a signal of “Ding-dong~” to ask a user to pay attention:

1. The contactor of Doppler Probe in use is disconnected from the main body (Er1) .
2. Out of paper during recording (Er2).
3. The switch is firstly on .
4. Set-up values are changed and stored.

In cases of 1 and 2 among the above circumstances, a signal of “Ding-dong~” will be continued until pressing any of keys on the operation panel. (See Paragraph 3 of Chapter 4 : Error Message)

## Chapter 3. Setup Modes

The setup modes include those of alarm/time, recording, and factory. The factory setup is a part having great effect on the performance of the equipment if the set-up value is easily changed; so it is somewhat hard for a user to access.

### 1) Alarm/Time Setup

It is a mode to set the upper and lowest limits of normal FHR, date, and time in terms of the FHR alarm function.

#### NOTE

FC1400 of alarm condition, patient alarm is higher than technical alarm system.

#### How to Operate the Alarm/Time Setup Mode

1. Press the Alarm key for over two seconds to change into the alarm/time setup mode.
2. Press the Reference key to move to the next item.
3. Press the VOLUME ▼▲key to change the set-up value.
4. Press the Record key to store the set-up value and then return it to the basic state.
5. Press the Alarm key to cancel the set-up value and then return it to the basic state.

#### How to Set the FHR Alarm

1. Press the Alarm key for over two seconds to set the upper limit of FHR alarm. Then the following appears which indicates that the current FHR upper limit is set at 190.



Premere il tasto VOLUME UP/DOWN per modificarne l'impostazione, Premere quindi il tasto RECORD per memorizzarle il nuovo valore. Poi, un segnale acustico confermerà l'avvenuta memorizzazione della nuova impostazione.

2. To set the lowest limit of FHR alarm, press the Alarm key for over two seconds and then the Reference key to indicate the following. It indicates that the current lowest value of FHR alarm is set at 110.



To change the set-up value, press the Volume Up/Down Key. To store the set-up value, press the Record key. Then, this value is stored and then it returns to the basic state with a signal of "Ding-dong".

## How to Set the Date and Time

1. To set the year, press the Alarm key for over two seconds and then the Reference key to indicate the following. It indicates that the current year is 2002.



Use the Volume Up/Down Key to change the year. Press the Record Key to store the changed value and then return it to the basic state after a signal of "Ding-dong".

2. To set the month, press the Alarm key for over two seconds and then the Reference key to indicate the following. It indicates that the current month is May.



Use the Volume Up/Down Key to change the month. Press the Record Key to store the changed value and then return it to the basic state after a signal of "Ding-dong".

3. To set the date, press the Alarm key for over two seconds and then the Reference key to indicate the following. It indicates that it is the 7th day now.



Use the Volume Up/Down Key to change the set-up date. Press the Record Key to store the changed value and then return it to the basic state after a signal of "Ding-dong".

4. To set the hour, press the Alarm key for over two seconds and then Reference key to indicate the following. It indicates "1 o'clock" now.



Use the Volume Up/Down Key to change the set-up hour. Press the Record Key to store the changed value and then return it to the basic state after a signal of "Ding-dong".

5. To set the minute, press the Alarm key for over two seconds and then the Reference key to indicate the following. It indicates "11 minutes" now.



Use the Volume Up/Down Key to change the set-up minute. Press the Record Key to store the changed value and then return it to the basic state after a signal of "Ding-dong".

## 2) Recording Setup

It is a mode to control the setup values of printing speed, grid indication, contrast, automatic NST function, and automatic fetal movement detection.

### How to Operate the Recording Setup Mode

1. Press the Reference key for over two seconds to change into the recording setup mode.
2. Press the Reference key for a short time at the recording setup mode to move to the next item.
3. Press the VOLUME ▼▲ key to change the set-up value.
4. Press the Record key to store the set-up value and then return it to the basic state.
5. Press the Alarm key to cancel the set-up value and then return it the basic state.

### How to Set the printing Speed, Grid Indication, and Contrast

1. To set the printing speed, press the Reference key for over two seconds and then for a short time to indicate the following. It indicates that the (output is at a speed of 3 centimeters a minute now.) printing speed is 3 cm/min now



The output speed can be set at one of 1, 2, and 3 cm/min, and may be changed with the Volume Up/Down Key.

2. Thermal paper for a facsimile can be used for FC-700 besides those supplied. To use those for a facsimile, press the Reference key for over two seconds and then for a short time to indicate the following. Select 0 for sheets supplied by this company and 1 for those for a facsimile, and use the Volume Up/Down Key to change it. If the set-up value is 1, Grid is printed at a sheet for a facsimile with a signal.



### NOTE

When use a paper just for fetal monitor, set-up value must be "0".

3. To control the contrast of graph, press the Reference key for over two seconds and then for a short time to indicate the following.



Select 1 for a medium and 2 for the darker state, and use the Volume Up/Down Key to change it.



**How to Set AUTO NST**

To set the AUTO NST function, press the Reference key for over two seconds and then for a short time to indicate the following.



As for '0', press the Record key at the basic state to print it and press it again to stop printing. Select '10' for 10-minute constant recording, '20' for 20-minute, '30' for 30-minute, '40' for 40-minute, '50' for 50 minute, and '60' for 60-minute, and recording will stop automatically after the set-up time. Press the Record key during recording to stop recording.

**How to Set the Automatic Fetal Movement Detection Function**

To set the automatic fetal movement detection function, press the Reference key for over two seconds and then for a short time to indicate the following.



Value '1' is [FM+FMD], '2' is [FMD only], and '0' is [Off].

**How to set Cardio-Toco Graph(CTG) analysis function**

Press REFERENCE button for at least 2 seconds and repress REFERENCE button for a short amount of time in order to set automatic CTG diagnosis function. It should appear like the figure below.



0' cancels CTG analysis function and '1' sets for CTG analysis function.

**How to set Protocol Type**

Press REFERENCE button for at least 2 seconds and repress REFERENCE button for a short amount of time in order to set protocol type. It should appear like the figure below.



- S1 : Serial protocol with FC Central I
- S2 : Serial protocol with FC Central II
- LA : Serial to Wi-fi protocol with FC Central II

## How to set Bed Number

Select the monitor's own identification number. This number will be used to identify the monitor within the central monitoring system. Press REFERENCE button for at least 2 seconds and repress REFERENCE button for a short amount of time in order to set Bed number. It should appear like the figure below. Use the Volume Up/Down Key to change it.



## How to set Demo mode

Press REFERENCE button for at least 2 seconds and repress REFERENCE button for a short amount of time in order to set Demo mode. It should appear like the figure below. Use the Volume Up/Down Key to change it. Value '1' is [On], '0' is [Off].



The screen indicating the demo operation as below periodically shows at FHR and UC during the Demo mode operation.



### 3) Factory Setup

#### How to Set the FHR Alarm Delay

To set the FHR alarm delay, switch it off (and then press the Volume Down key) and switch it on again pressing the Volume Up key. Then, the following appears which indicates that the alarm delay time ('t') is set at ten minutes.



The set-up value of alarm delay is at six levels—10, 20, 30, 40, 50, and 60—and its unit is a second. When the alarm is on, FHR exceeds the established alarm delay; thus, an alarm of “Beep, beep, beep~” is made when it is beyond the upper/lowest limit of FHR alarm. The factory value is set at 20. Press the Volume Up/Down Key to change the set-up value. Press the Record key to store the set-up value. Then, this value is stored and then returns to the basic state with a signal of “Ding-dong”.

#### How to Set the Automatic Fetal Movement Indication

To set the automatic fetal movement indication, switch it off, and then switch it on again with the Volume Down key pressed. Then, the following is indicated.



The set-up value of automatic fetal movement indication can be between 0, 5, ..., 90, and 95, and its unit is percent (%). When the Doppler signal exceeds the set-up value during operation, marks with a dot indicating the fetal movement point between FHR and UC. When the set-up value is 0, doesn't mark with a dot. To change the set-up value, press the Volume Up/Down Key. To store the set-up value, press the Record key. Then, this value is stored and then it returns to the basic state with a signal of “Ding-dong”.

## Chapter 4. CTG Terminology

### 1) Baseline FHR

Mean FHR rounded to increments of 5 bpm during a 10 minute segment excluding periodic or episodic changes, periods of marked variability and, segments of baseline that differ by >25bpm. Duration must be  $\geq 2$  minutes.

### 2) ACCELERATION

Visually apparent abrupt increase (onset to peak is < 30sec) of FHR above baseline. Peak is  $\geq 15$  bpm. Duration is  $\geq 15$  bpm and < 2 min. Peak of 10 bpm and duration 10sec is acceleration.

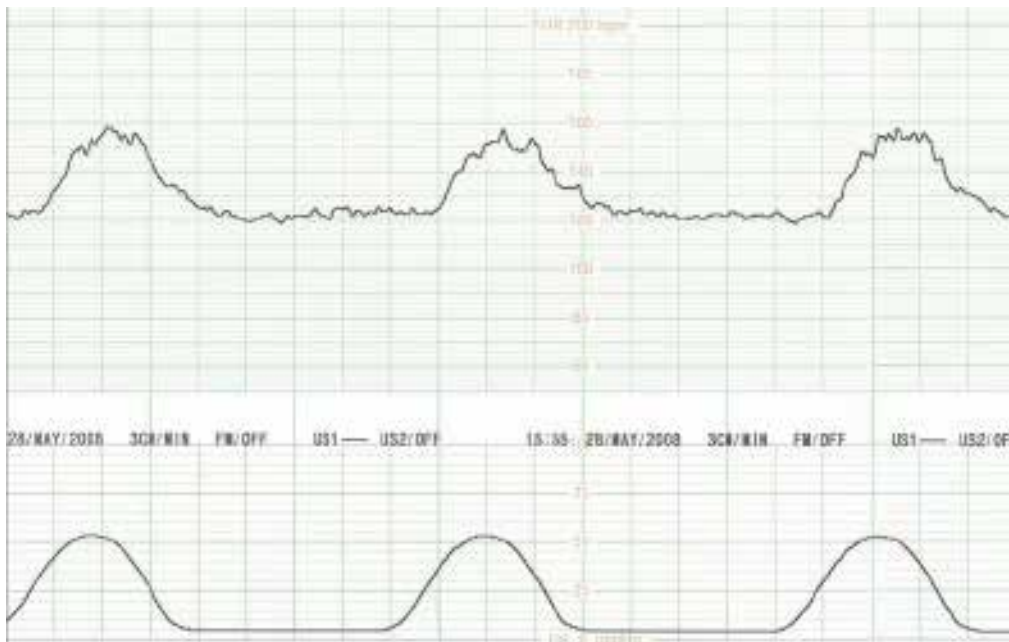

### 3) LATE DECELERATION

Visually apparent gradual decrease (onset to nadir is  $\geq 30$  sec.) of FHR below baseline. Return to baseline associated with a uterine contraction. Nadir of deceleration occurs after the peak of the contraction. Generally, the onset, nadir and recovery of the deceleration occur after same time as the onset, peak, and recovery of the contraction

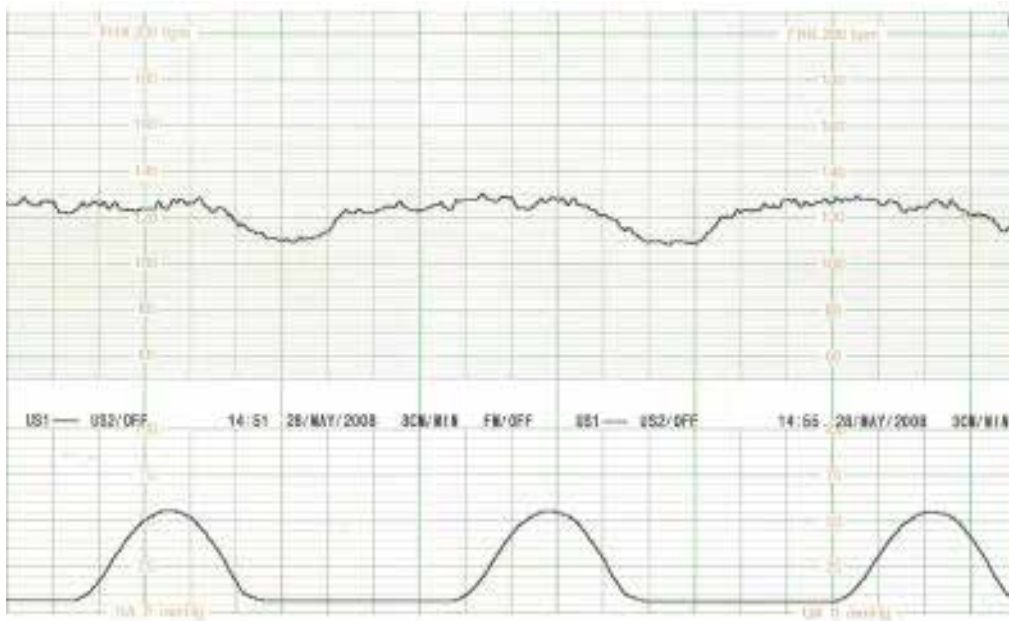

#### 4) EARLY DECELERATION

Visually apparent gradual decrease (onset to nadir is  $\geq 30$  sec.) of FHR below baseline. Return to baseline associated with a uterine contraction. Nadir of deceleration occurs at the same time as the peak of the contraction. Generally, the onset, nadir, and recovery of the deceleration occur at the same time as the onset, peak and recovery of the contraction.

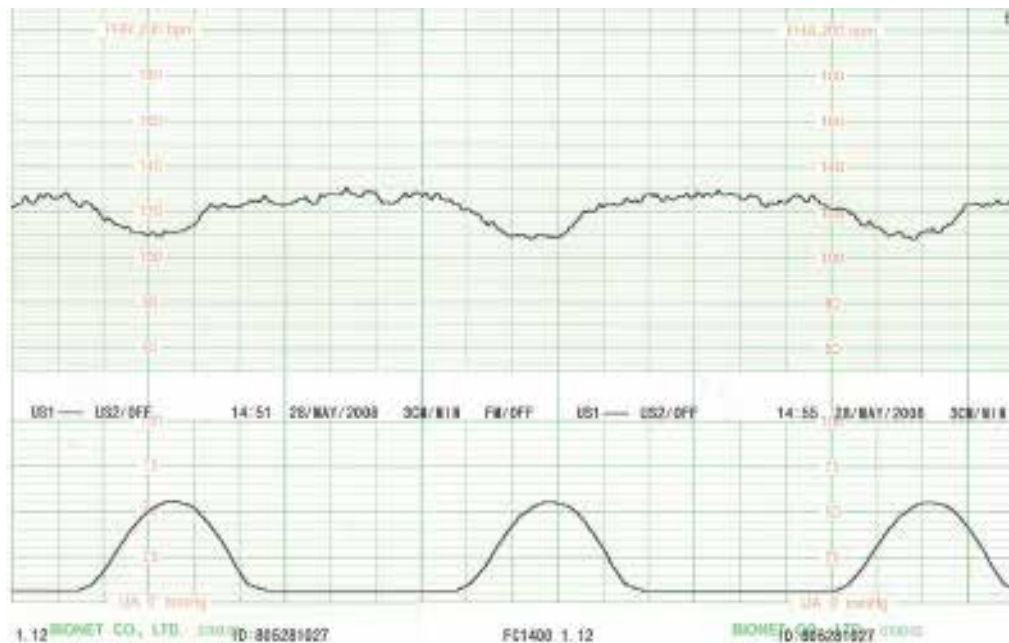

## 5) VARIABLE DECELERATION

Visually apparent abrupt decrease (onset to nadir is <30sec) in FHR below baseline. Decrease is  $\geq 15$  bpm. Duration is  $\geq 2$  min and < 10 min.

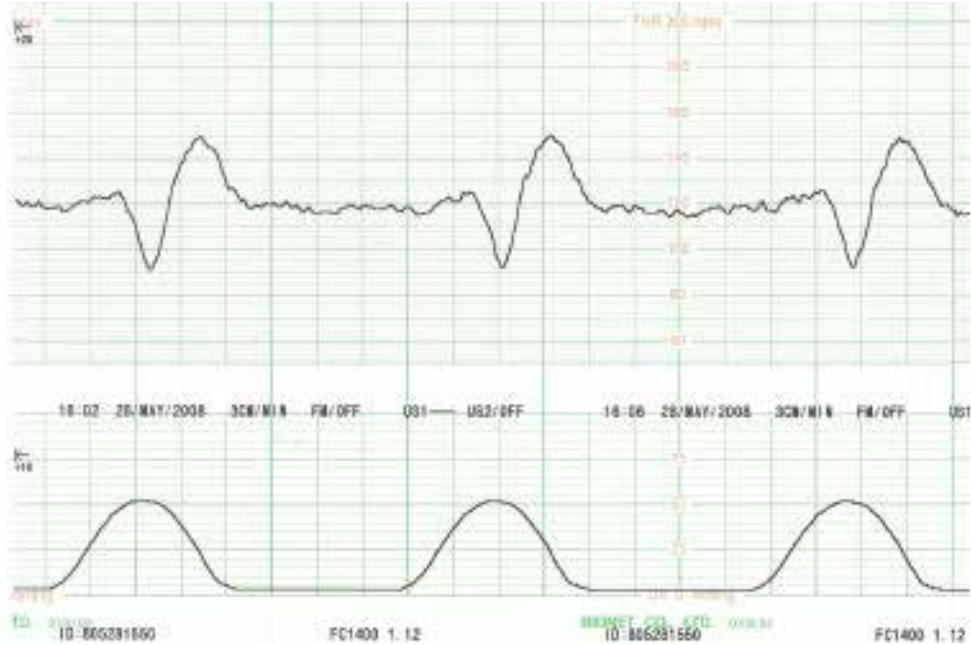

# Chapter 5. Trouble shooting

## 1) Maintenance and Cleaning

You can keep FC-700 clean in many different ways. Use the following recommendations to avoid the damage or stain to the machine. If the material (not approved material) that may cause damage to the product is used, the product is not gua-

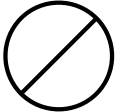
PROHIBITION	
	<p>Check the main unit and probes thoroughly after cleaning.</p> <p>Do not use the old and damaged equipment.</p> <p>Only Service person has to repair an equipment.</p>

ranteed even within the period of guarantee is not expired. To keep the machine clean, apply alcohol on a soft cloth and scrub the body and the measuring probes once a month. Do not use lacquer, thinner, ethylene, or the oxidizing substance. Keep the cable from dust or stain. Wipe the cable with a soaked cloth that is wet with warm water (40°C/ 104 F), and with the clinical alcohol once a week. Do not soak the machine or the probe cable into any liquid or detergent. Keep the machine or the probe cable away from any liquid.

### Recommended cleaning agents:

Alcohol (Ethanol 70%, Isopropanol 70%, Probes).

Ammonias (Dilution of ammonia <3%, Window cleaner).

Tensides (dishwasher detergents) (Edisonite schnellreiniger®, Alconox® ).

### Disinfecting

Do not mix disinfecting solutions (such as bleach and ammonia) as hazardous gases may result.

Clean equipment before disinfecting.

Recommended disinfecting agents: Aldehyde based (Cidex® activated dialdehyde solution, Gigasept )

Alcohol base (Ethanol 70%, Isopropanol 70%, Spitacid®, Streilium fluid®, Cutasept®, Hospisept®, Tinktur forte, Sagrosept®, Kodan®

## Disposal of your old appliance

1. When this crossed out wheeled bin symbol is attached to a product it means the product is covered by the European Directive 2002/96/EC.
2. All electrical and electronic products should be disposed of separately from the municipal waste stream via designated collection facilities appointed by the government or the local authorities.
3. The correct disposal of your old appliance will help prevent potential negative consequences for the environment and human health.
4. For more detailed information about disposal of your old appliance, please contact your city office, waste disposal service or the shop where you purchased the product.
5. instructions indicated the responsibility of the RESPONSIBLE ORGANIZATION to comply with international, regional or national regulations concerning environmental protection.
6. Maintenance of equipment

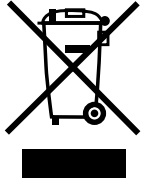

- 1) When DOP Probe does NOT work, it is connected to the other channel or exchange the DOP Probe. Also equal UC Probe.
- 2) If equipment does NOT work, you have to make a phone call service person of GIMA SPA.  
For more information, see the Service Manual.

## 2) Regular Inspection

Perform the periodical safety inspection on FC-700 once a year. For the inspection details, see the service manual provided by GIMA SPA.

## 3) Error Message

- A. If the Doppler probe comes off from the connector during monitoring, information sound (“Ding-Dong”) rings and the error message(Er1) is displayed. To solve this problem, connect the Doppler probe or press the VOLUME UP/DOWN key simultaneously.
- B. If the paper is used up during printing, information sound (“Ding-Dong”) rings and the error message(Er2) is displayed. To solve this problem, insert the paper or press the VOLUME UP/DOWN key simultaneously.



# Chapter 6. Specifications

## Environmental Specifications

Operating Temperature: 15°C to 30°C (59°F to 86°F).

Storage Temperature: - 10°C to 60°C (14°F to 140°F).

Operating/Storage Humidity: 20% to 95% RH, non-condensing.

Operating Altitude: 70(700) to 106Kpa(1060mbar).

## Power Specifications

Power Adaptor: BPM050S18F02 BRidgePower Corp.

Input: 100~240V, 50~60Hz, 1.2A.

Output: 18V, 2.8A.

Power Fail Protection.

Battery: CR 2032 3V Lithium battery.

## Performance Specifications

### *FHR Measurement*

Input signal: Ultrasound Pulsed Doppler.

Ultrasound Frequency: 1.0 MHz.

Ultrasound Power: 0.87mW/cm<sup>2</sup>.

FHR Detection Method: Auto Correlation.

Measurement Range: 50 ~ 240 beats per minutes(BPM).

FHR Accuracy: ±1 bpm over normal FHR range.

Ultrasound Sensitivity: 95dB at 150mm.

### *UC Measurement*

Input Source: External Transducer with strain gauge.

Frequency Response: DC ~ 0.5 Hz.

Reference(Zero) Control: One touch switch.

Measurement Range: 0 ~ 99 units.

2g = 1unit

## Fetal Movement Measurement

Detection Source: Ultrasound Pulsed Doppler.

Recording Method:

1. Spike-like waveform on UC channel denotes relative intensity and duration of Fetal Movement.
2. Dot marks between FHR and UC channels when FM intensity exceeds selected threshold.

## Recorder

Recorder Method: Thermal Array Type.

Resolution: 8(vertical)/10(horizontal) dot/mm.

Print Speed: 1, 2, 3 cm/min.

Paper Feeding Function.

Paper Grid: On/Off.

Print Contrast: 1, 2.

Auto Print Period: 0, 10, 20, 30, 40, 50, 60.

Fetal movement: On/Off.

## Display

7-Segment LED.

2 Channels (FHR, UC).

## Indicators

Heart Rhythm (Green: Stable, Red: Unstable).

Alarm On/Off State.

Print On/Off State.

AC Power (Green LED).

## Sound

Doppler Sound with Volume Control (8 steps)

Alarms Sound:

Information Sound: Dop Probe off, Paper off, Watch Dog, Set-up Data Storage

NST End.

## Set-up

Alarm Upper/Lower Limit Value.

Alarm check delay time.

Print Speed.

Paper Grid.

Print Contrast.

Auto Print Period(NST time).

Time / Date.

Fetal Movement OFF/FMD+FM/FMD Only.

Fetal Movement Detection Threshold.

Demo ON/OFF.

BED Number.

CTG ON/OFF.

## Function

Event Mark Function.

## External Link

RS232C: Program Down Load, Central (Option).

# Appendix A Maintenance, Care, and Service

## MECHANICAL HAZARD

### WARNING



Ultrasound probes are highly sensitive medical instruments that can easily be damaged by improper handling. Use care when handling and protect from damage when not in use. DO NOT use a damaged or defective probe. DO NOT drop the probes or subject them to other types of mechanical shock or impact.

### WARNING



A defective probe or excessive force can cause patient injury or probe damage:

- Observe depth markings and do not apply excessive force when inserting or manipulating intercavitary probes.
- Inspect probes for sharp edges or rough surfaces that could injure sensitive tissue.
- DO NOT apply excessive force to the probe connector when inserting into the probe port. The pin of a probe connector may bend.

## BIOLOGICAL HAZARD

### WARNING



To avoid the risk of disease transmission:

- Must use protective barriers (gloves and probe sheaths). Follow sterile procedures when appropriate.
- Thoroughly clean probes and reusable accessories after each patient examination and disinfect or sterilize as needed.
- Follow all infection control policies established by your office, department or institution as they apply to personnel and equipment.

**ELECTRICAL HAZARD**

<b>WARNING</b>	
	<p>In case Gel contacts internal electronic device, Defective probe may cause electrical shock. Prior to each use, visually inspect the probe lens and case area for cracks, cuts, tears, and other signs of physical damage.</p> <p>DO NOT use a probe which appears to be damaged until you verify functional and safe performance.</p> <p>Perform a more thorough inspection, including the cable, and connector, each time clean the probe.</p> <p>DO NOT kink, tightly coil, or apply excessive force on the probe cable. Insulation failure may result.</p> <p>Warning statement for class i me equipment indicating: “warning: To avoid risk of electric shock, this equipment must only be connected to a supply mains with protective earth”                      “Do not modify this equipment without authorization of the manufacturer”                      “warning: If this equipment is modified, appropriate inspection and testing must be conducted to ensure continued safe use of equipment”</p> <p>Do not to touch signal input, signal output or other connectors, and the patient simultaneously. Refer servicing to qualified personnel of GIMA SPA.</p>

**PROBE ACOUSTIC OUTPUT HAZARD**

<b>WARNING</b>	
	<p>Ultrasound can produce harmful effects in tissue and potentially result in patient injury. Always minimize exposure time. and keep ultrasound levels low when there is no medical benefit.</p>

**PROBE HEAD WATERPROOF**

<b>MANDATORY ACTION</b>	
	<p>From probe bottom to 2~3 cm, waterproof IPX is possible. Do NOT immerse the probe bottom into any liquid beyond 2~3 cm from probe bottom. Never immerse the probe connector into any liquid.</p>

# Appendix B Ultrasound Power

## Use of Diagnostic Ultrasound

The American Institute of Ultrasound in Medicine (AIUM) has published a document entitled “Medical Ultrasound Safety”. This three part document covers Bioeffects and Biophysics, prudent Use and Implementing ALARA. Ultrasound users should read the AIUM documents to become more familiar with Ultrasound safety. A copy of this document is included as part of the documentation package (Document 2163920-100).

AIUM  
 14750 Sweitzer Lane, Suite 100  
 Laurel, MD, USA 20707-5906  
 telephone 1-800-638-5352.

In accordance with US FDA Guidelines, the overall maximum acoustic SPTA intensity for the product is limited to 100 mW/cm<sup>2</sup> and MI is limited to 1.0.

## MEASUREMENT PRECISION AND UNCERTAINTY

	Center Frequency	Acoustic Power	Peak Rarefractional Pressure	Acoustic Intensity
Measurement Uncertainty	+/- 2%	+/- 5%	+/- 15%	+/- 25%

## MAXIMUM OUTPUT SUMMARY

Operating Mode	DOP Probe
Pulsed Doppler Mode	O

## MAXIMUM PROBE TEMPERATURE (DEGREES C)

	Probe		Max Temperature	
	With TMM Phantom	In Air	Mode	
US	33.8	23	PWD Mode	

Lens temperature monitored for 30 min.  
 Measurement uncertainty: +/-0.5 degree C.  
 Ambient temperature: 23.5 degree C.

# FETAL MONITOR FC-700 OPERATING MANUAL

IEC	FDA	Meaning IEC60601-2-37 / FDA&NEMA UD2,UD3
$\alpha$	a	Acoustic Attenuation Coefficient / Derating factor (usually 0.3 dB/cm-MHz)
Aaprt	Aaprt	-12db Output Beam Area / Active aperture area
CMI	-	Normalizing Coefficient
Deq	Deq	Equivalent Aperture Diameter
d-6	d-6	Pulse Beam Width / Beam diameter at -6 dB
deq	deq	Equivalent Beam Diameter
fawf	fc	Acoustic Working Frequency / Center frequency
Ipa	Ipa	Pulse-Average Intensity
Ipa, $\alpha$	Ipa.3	Attenuated Pulse-Average Intensity
Ipi	PII	Pulse-Intensity Integral
Ipi, $\alpha$	PII.3	Attenuated Pulse-Intensity Integral
Ita(z)	ITA	Temporal-Average Intensity
Ita, $\alpha$ (z)	ITA.3(Z)	Attenuated Temporal-Average Intensity at depth z
Izpta(z)	ISPTA(Z)	Spatial-Peak Temporal-Average Intensity
Izpta, $\alpha$ (z)	ISPTA.3(Z)	Attenuated Spatial-Peak Temporal-Average Intensity
MI	MI	Mechanical Index
P	Wo	Output Power / Time average acoustic power at the source
P $\alpha$	W.3(Z)	Attenuated Output Power / Time average acoustic power derated to depth z
P1	Wo1	Bounded Output Power / Power emitted from the central 1cm of aperture
pi	PII	Pulse Pressure Squared Integral / Pulse intensity integral
pr	pr	Peak-Rarefactional Acoustic Pressure
pr $\alpha$	pr.3	Attenuated Peak-Rarefactional Acoustic Pressure
prr	PRF	Pulse Repetition Rate / Pulse repetition frequency
TI	TI	Thermal Index
TIB	TIB	Bone Thermal Index
TIC	TIC	Cranial-Bone Thermal Index
TIS	TIS	Soft-Tissue Thermal Index
td	PD	Pulse Duration
X, Y	x-12,y-12	-12 dB Output Beam Dimensions
Z	Z	Distance from the Source to a Specified Point
Zb	Zsp	Depth for TIB / Depth at which the relevant index is maximum
Zbp	Zbp	Break-Point Depth
Zs	Zsp	Depth for TIS / Depth at which the relevant index is maximum

ACOUSTIC OUTPUT TABLES  
MC65R1S – PULSED DOPPLER MODE

Index				MI	TIS			TIB	TIC	
					scan	Non-scan		Non-scan		
						Aaprt<= 1	Aaprt > 1			
Global Maximum : Index Value				0.014874	-	0.010587	-	0.168265	0.178513	
	IEC	FDA	Unit							
Associated	pra	pr.3	(MPa)	0.0148732						
Acoustic	P	Wo	(mW)		-	43.7		43.7	43.7	
Parameter	min of [Pa(zs), I <sub>ta,α</sub> (zs)]	min of [(W.3(Z1), ITA.3(z1)]	(mW)				-			
	zs	z1	(cm)							
	zbp	zbp	(cm)							
	zb	zsp	(cm)	12.226				12.226		
	z at max. I <sub>pi,α</sub>	zsp	(cm)							
	deq(zb)	deq(zsp)	(cm)					3.28258		
	fawf	fc	(MHz)	0.999891	-	0.999891	-	0.999891	0.999891	
	Dim of Aaprt	X	(cm)		-	6.12	-		6.12	6.12
		Y	(cm)		-	6.12	-		6.12	6.12
	Other	td	PD	(μsec)	93.3692					
Information	prf	PRF	(Hz)	4000						
	pr at max. I <sub>pi</sub>	pr@P <sub>l</sub> max	(MPa)	0.0202734						
	deq at max. I <sub>pi</sub>	deq@P <sub>l</sub> max	(cm)					3.2769		
	Focal Length	FLX	(cm)		-	0	-			0
		FLY	(cm)		-	0	-			0
	I <sub>pa,α</sub> at max. MI	IPA.3@M <sub>l</sub> max	(W/cm <sup>2</sup> )	0.00521243						
Operating	Frequency		(MHz)	1.0	-	1.0	-	1.0	1.0	
Control Conditions										

# Appendix C Abbreviation and Symbol

## Abbreviazioni

### A

AC alternating current

### B

### C

C Celsius

cm, CM centimeter

### D

DC direct current

### E

EMC electromagnetic compatibility

EMI electromagnetic interference

### F

F Fahrenheit

### G

g gram

### H

HR heart rate, hour

Hz hertz

### I

Inc incorporated

### J

### K

kg, KG kilogram

### L

L liter, left

lbs, LBS pounds

LCD liquid crystal display

LED light emitting diode

### M

M mean, minute

m meter

MIN, min minute

MM, mm millimeters

MM/S millimeters per second

MMHG, mmHg millimeters of mercury

mV millivolt

### N

### O

### P

### Q

### R

### S

sec second

### T

Temp, TEMP temperature

### U

### V

V volt

### W

### X

X multiplier when used with a number (2X)

### Z

## Symbols

& and

° degree(s)

> greater than

< less than

– minus

# number

% percent

±, +/- plus or minus



# Appendix D Electromagnetic Emissions and Immunity - Manufacturer's declaration

## ELECTROMAGNETIC EMISSIONS AND IMMUNITY

### MANUFACTURER'S DECLARATION - ELECTROMAGNETIC EMISSION

The FC-700 system is intended for use in the electromagnetic environment specified below. The customer or the user of FC-700 system should assure that it is used in such an environment		
Emission test	Compliance	Electromagnetic environment guidance
RF emissions CISPR 11	Group 1	The FC-700 system uses RF energy only for its internal function. Therefore. Its RF emissions are very low and are not likely to cause any interference in nearby electronic equipment.
RF emissions CISPR 11	Class B	The FC-700 system is suitable for use in all establishments including domestic and those directly connected to the public low-voltage power supplies buildings used for domestic purposes.
Harmonics emission IEC 61000-3-2	A	
Voltage fluctuation IEC 61000-3-3	Complies	

**MANUFACTURER'S DECLARATION - ELECTROMAGNETIC IMMUNITY**

The FC-700 system is intended for use in the electromagnetic environment specified below. The customer or the user of the FC-700 system should assure that it is used in such an environment

<b>Immunity test</b>	<b>IEC 60601 Test level</b>	<b>Compliance level</b>	<b>Electromagnetic Environment -guidance</b>
Electrostatic discharge (ESD) IEC 61000-4-2	6 kV Contact 8 kV Air	6 kV Contact 8 kV Air	Floors should be wood, concrete or ceramic tile. If floors are covered with synthetic material, the relative humidity should be at least 30 %
Electrical fast Transient / burst IEC 61000-4-4	2kV for power supply lines 1kV for input/output lines	2kV for power supply lines 1kV for input/output lines	Mains power quality should be that of a typical commercial or hospital environment.
Surge IEC 61000-4-5	1 kV differential mode 2 kV common mode	1 kV differential mode 2 kV common mode	Mains power quality should be that of a typical commercial or hospital environment.
Power frequency (50/60Hz) Magnetic field IEC 61000-4-8	3.0 A/m	3.0 A/m	Power frequency magnetic fields should be at levels characteristic of a typical location in a typical commercial or hospital environment.
Voltage dips, short Interruptions and Voltage variations on power supply input lines IEC 61000-4-11	<5% $U_T$ (>95% dip in $U_T$ ) for 0.5cycle  40% $U_T$ (60% dip in $U_T$ ) for 5 cycle  70% $U_T$ (30% dip in $U_T$ ) for 25 cycle  <5% $U_T$ (<95% dip in $U_T$ ) for 5 s	<5% $U_T$ (>95% dip in $U_T$ ) for 0.5cycle  40% $U_T$ (60% dip in $U_T$ ) for 5 cycle  70% $U_T$ (30% dip in $U_T$ ) for 25 cycle  <5% $U_T$ (<95% dip in $U_T$ ) for 5 s	Mains power quality should be that of a typical commercial or hospital environment. If the user of the FC-700 system requires continued operation during power mains interruptions, it is recommended that the FC-700 system be powered from an uninterruptible power supply or a battery.

**Note:**  $U_T$  is the a.c. mains voltage prior to application of the test level.

The FC-700 system is intended for use in the electromagnetic environment specified below. The customer or the user of the FC-700 system should assure that it is used in such an environment

Immunity test	IEC 60601 Test level	Compliance level	Electromagnetic environment - guidance
Conducted RF IEC 61000-4-6	3 Vrms 150 kHz to 80 MHz	3 Vrms 150 kHz to 80 MHz	Portable and mobile RF communications equipment should be used no closer to any part of the FC-700 system, including cables, than the recommended separation distance calculated from the equation applicable to the frequency of the transmitter. <b>Recommended separation distance:</b> $d = \left[ \frac{3.5}{V_1} \right] \sqrt{P}$
Radiated RF IEC 61000-4-3	3 V/m 80.0 MHz to 2.5 GHz	3 V/m 80.0 MHz to 2.5 GHz	<b>Recommended separation distance</b> $d = \left[ \frac{3.5}{E_1} \right] \sqrt{P} \quad 80 \text{ MHz to } 800 \text{ MHz}$ $d = \left[ \frac{7}{E_1} \right] \sqrt{P} \quad 800 \text{ MHz to } 2.5 \text{ GHz}$ <p>Where P is the maximum output power rating of the transmitter in watts (W) according to the transmitter manufacturer and d is the recommended separation distance in meters (m). Field strengths from fixed RF transmitters, as determined by an electromagnetic site survey,                      (a) Should be less than the compliance level in each frequency range (b).                      Interference may occur in the vicinity of equipment marked with the following symbol:</p> <div style="text-align: center;">  </div>

**Note 1)**  $U_T$  is the A.C. mains voltage prior to application of the test level.

**Note 2)** At 80 MHz and 800 MHz, the higher frequency range applies.

**Note 3)** These guidelines may not apply in all situations. Electromagnetic propagation is affected by absorption and reflection from structures, objects and people.

**a** Field strengths from fixed transmitters, such as base stations for radio (cellular/cordless) telephones and land mobile radios, amateur radio, AM and FM radio broadcast and TV broadcast cannot be predicted theoretically with accuracy. To assess the electromagnetic environment due to fixed RF transmitters, an electromagnetic site survey should be considered. If the measured field strength in the location in which the EUT is used exceeds the applicable RF compliance level above, the EUT should be observed to verify normal operation. If abnormal performance is observed, additional measures may be necessary, such as re-orienting or relocating the EUT.

**b** Over the frequency range 150 kHz to 80 MHz, field strengths should be less than  $[V_1] \text{ V / m}$ .

## FETAL MONITOR FC-700 OPERATING MANUAL

### Recommended Separation Distances Between Portable and Mobile RF Communications Equipment and the FC-700 system.

**The FC-700 system is intended for use in an electromagnetic environment in which radiated RF disturbances are controlled. The user of the FC-700 system can help prevent electromagnetic interference by maintaining a minimum distance between portable and mobile RF communications equipment (transmitters) and the FC-700 system as recommended below, according to the maximum output power of the communications equipment.**

Rated maximum output power (W) of transmitter.	Separation distance (m) according to frequency of transmitter.		
	150 kHz to 80 MHz	80 MHz to 800 MHz	800 MHz to 2.5 GHz
0.01	0.12	0.12	0.23
0.1	0.37	0.37	0.74
1	1.17	1.17	2.33
10	3.70	3.70	7.37
100	11.70	11.70	23.30

For transmitters rated at a maximum output power not listed above, the recommended separation distance (d) in meters (m) can be estimated using the equation applicable to the frequency of the transmitter, where P is the maximum output power rating of the transmitter in watts (W) according to the transmitter manufacturer.

Note 1: At 80 MHz and 800 MHz, the separation distance for the higher frequency range applies

Note 2: These guidelines may not apply in all situations. Electromagnetic propagation is affected by absorption and reflection from structures, objects, and people.

### Immunity and Compliance Level

Immunity test	IEC 60601 Test Level	Actual Immunity Level	Compliance Level
Conducted RF IEC 61000-4-6	3 Vrms, 150 kHz to 80 MHz	3 Vrms, 150 kHz to 80 MHz	3 Vrms, 150 kHz to 80 MHz
Radiated RF IEC 61000-4-3	3 V/m, 80 MHz to 2.5 GHz	3 V/m, 80 MHz to 2.5 GHz	3 V/m, 80 MHz to 2.5 GHz

**GUIDANCE AND MANUFACTURER'S DECLARATION - ELECTROMAGNETIC IMMUNITY**

The FC-700 system is intended for use in the electromagnetic environment specified below. The customer or the user of the FC-700 system should assure that it is used in such an environment

Immunity test	IEC 60601 Test level	Compliance level	Electromagnetic environment - guidance
Conducted RF IEC 61000-4-6	3 Vrms 150 kHz to 80MHz	3 Vrms 150 kHz to 80MHz	FC-700 system must be used only in a shielded location with a minimum RF shielding effectiveness and, for each cable that enters the shielded location with a minimum RF shielding effectiveness and, for each cable that enters the shielded location.
Radiated RF IEC 61000-4-3	3 V/m 80.0 MHz to 2.5 GHz	3 V/m 80.0 MHz to 2.5 GHz	Field strengths outside the shielded location from fixed RF transmitters, as determined by an electromagnetic site survey, should be less than 3V/m.a Interference may occur in the vicinity of equipment marked with the following symbol:  

**Note 1)** These guidelines may not apply in all situations. Electromagnetic propagation is affected by absorption and reflection from structures, objects and people.

**Note 2)** It is essential that the actual shielding effectiveness and filter attenuation of the shielded location be verified to assure that they meet the minimum specification.

**a** Field strengths from fixed transmitters, such as base stations for radio (cellular/cordless) telephones and land mobile radios, amateur radio, AM and FM radio broadcast and TV broadcast cannot be predicted theoretically with accuracy. To assess the electromagnetic environment due to fixed RF transmitters, an electromagnetic site survey should be considered. If the measured field strength outside the shielded location in which the EUT is used exceeds 3V/m, the EUT should be observed to verify normal operation. If abnormal performance is observed, additional measures may be necessary, such as relocating the EUT or using a shielded location with a higher RF shielding effectiveness and filter attenuation.

**PRODUCT WARRANTY**

<b>Product Name</b>	<b>Fetal Care</b>
<b>Model Name</b>	<b>FC-700</b>
<b>Approval No.</b>	
<b>Approval Date</b>	
<b>Serial No.</b>	
<b>Warranty Period</b>	<b>1 years from date of purchase (Two years in Europe)</b>
<b>Date of Purchase</b>	
<b>Customer</b>	<b>Hospital :</b> <b>Address :</b> <b>Name :</b> <b>Tel :</b>
<b>Sales Agency</b>	
<b>Manufacturer</b>	

Thank you for purchasing FC-700.

This product is manufactured and passed through strict quality control and inspection.

Compensation standard concerning repair, replacement, refund of the product complies with "Consumer's protection law" noticed by Economic Planning Dept.

**Manufactured by - Bionet Co., Ltd:**

#1101 11F E&C Venture Dream Tower3, 38-21, Digital-Ro, 31-Gil,  
Guro-Gu, Seoul 08376, REPUBLIC OF KOREA  
Tel : +82-70-7585-6418 / Fax: +82-2-6499-7789 / e-mail: sales@ebionet.com  
Website: www.ebionet.com

**Sales & Service Representative:**

**GIMA SPA**

VIA MARCONI 1 – 20060 GESSATE (MI) ITALY  
Tel : ++39 02 953854209 / Fax: ++39 02 95380056 / E-mail: export@gimaitaly.com  
Website: <http://www.gimaitaly.com>

**GIMA SPA**

Model Name: FC-700

Rev. 2.51



0123



BIONET Co., Ltd. #1101, E&C Venture Dream Tower3 38-21,  
Digital-Ro, 31-Gil, Guro-Gu, Seoul 08376,  
REPUBLIC OF KOREA



MGB Endoskopische Geräte GmbH Berlin, Schwarzschildstr. 6,  
12489 Berlin - GERMANY